



# OWNER/OPERATOR'S MANUAL & ILLUSTRATED PARTS LIST

---

**MODEL:**

**73-70632 LAWN SWEEPER LS340**



*WARNING: If incorrectly used this machine can cause severe injury. Those who use and maintain this machine should be trained in its proper use, warned of its dangers and should read the entire manual before attempting to set up, operate, adjust or service the machine.*

---



**09-164 REV B**

**CALIFORNIA  
Proposition 65 Warning**

Diesel engine exhaust and some of its constituents are known to the State of California to cause cancer, birth defects and other reproductive harm.

 **WARNING**

The engine exhaust from this product contains chemicals known to the State of California to cause cancer, birth defects or other reproductive harm.

**Californie Proposition 65  
Avertissement**

Les échappements des moteurs diesel et certains de leurs composés sont reconnus par l'Etat de Californie pour être cancérigènes, provoquer des défauts congénitaux et d'autres dangers en matière de reproduction.

 **AVERTISSEMENT**

L'émission du moteur de ce matériel contient des produits chimiques que l'Etat de Californie considère être cancérigènes, provoquer des défauts congénitaux et d'autres dangers en matière de reproduction.

**California Advertencia  
de la Proposicion 65**

El estado de California hace saber que los gases de escape de los motores diesel y algunos de sus componentes producen cáncer, defectos de nacimiento y otros daños en el proceso de reproducción humana.

 **ADVERTENCIA**

El estado de California hace saber que los gases de escape de este producto contienen productos químicos que producen cáncer, defectos de nacimiento y otros daños en el proceso de reproducción humana.

# LAWN SWEEPER

## IMPORTANT MESSAGE

Thank you for purchasing this Jacobsen product. You have purchased a world class product, one of the best designed and built anywhere.

This product comes with an Owner/Operator's Manual. The useful life and good service you receive from this product depends to a large extent on how well you read and understand this manual. Treat this product properly and adjust it as instructed, and it will give you many years of reliable service.

See a Jacobsen dealer for any service or parts needed. Jacobsen service ensures that you continue to receive the best results possible from Jacobsen products. You can trust Jacobsen replacement parts because they are manufactured with the same high precision and quality as the original parts.

Jacobsen designs and builds its equipment to serve many years in a safe and productive manner. For longest life, use this product only as directed in the manual, keep it in good repair and follow safety warnings and instructions. You'll always be glad you did.

**Jacobsen, a Textron Company**  
**One Bob Cat Lane**  
**Johnson Creek, WI 53038-0469**

<b>TABLE OF CONTENTS</b>	<b>FIGURES</b>	<b>PAGE</b>
INTRODUCTION / SPECIFICATIONS .....		2
SAFETY .....		3, 4
OPERATION / SERVICE .....		5
MAIN PARTS .....	FIGURE 1 .....	6, 7
BRUSH PARTS .....	FIGURE 2 .....	8, 9

## DESCRIPTION

The Lawn Sweeper is designed to give a “clean sweep” in your lawn sweeping operations. The unit is ground-driven so it can be pulled by any lawn and garden tractor. It can be used to trail behind with offset hitch while mowing, or regular hitch to clean-up after you’ve finished mowing. The packing action allows you to put much more material into the unit before it is necessary to unload.

There is a transport position for the sweeper and clutch levers on each wheel to disengage the wheel clutches.

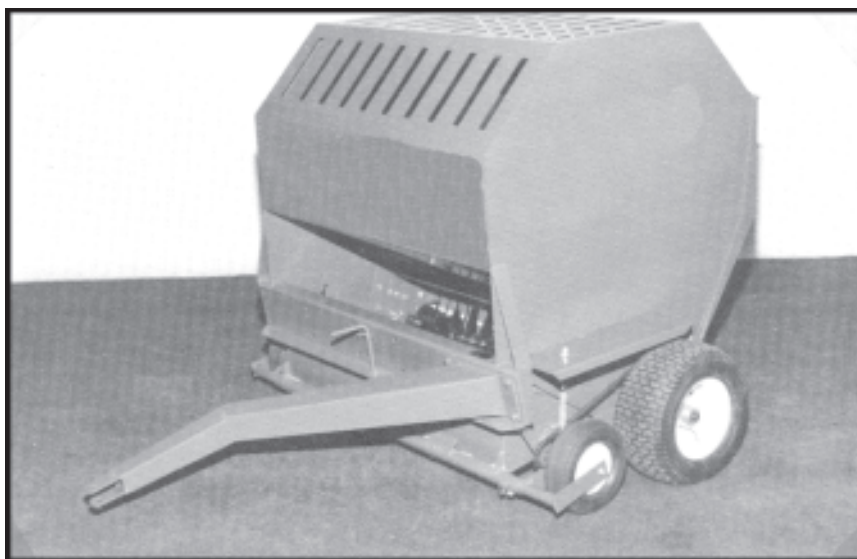

## SPECIFICATIONS

Overall Width .....	62"
Overall Height .....	52"
Overall Length to Hitch .....	66"
Width of Pick Up .....	40"
Brush .....	3 paddle, staggered
Depth Wheels .....	Semi-pneumatic
Hitch .....	Right, left or center pull adjustment
Carrying Capacity .....	24 cu. ft.
Weight .....	530 lbs.

## NOTICE !!!

Unauthorized modifications may present **extreme** safety hazards to operators and bystanders and could also result in product damage.

Jacobsen, a Textron Company strongly warns against, rejects and disclaims any modifications, add-on accessories or product alterations that are not designed, developed, tested and approved by Jacobsen Engineering Department. Any Jacobsen product that is altered, modified or changed in any manner not specifically authorized after original manufacture—including the addition of “after-market” accessories or component parts not specifically approved by Jacobsen—will result in the Jacobsen Warranty being voided.

Any and all liability for personal injury and/or property damage caused by any unauthorized modifications, add-on accessories or products not approved by Jacobsen will be considered the responsibility of the individual(s) or company designing and/or making such changes. Jacobsen will vigorously pursue full indemnification and costs from any party responsible for such unauthorized post-manufacture modifications and/or accessories should personal injury and/or property damage result.



This symbol means:  
**ATTENTION!**  
**BECOME ALERT!**

Your safety and the safety of others is involved.

## Signal word definitions:

The signal words below are used to identify levels of hazard seriousness. These words appear in this manual and on the safety labels attached to Jacobsen machines. For your safety and the safety of others, read and follow the information given with these signal words and/or the symbol shown above.

### **DANGER**

**DANGER** indicates an imminently hazardous situation which, if not avoided, **WILL** result in death or serious injury.

### **WARNING**

**WARNING** indicates a potentially hazardous situation which, if not avoided, **COULD** result in death or serious injury.

### **CAUTION**

**CAUTION** indicates a potentially hazardous situation which, if not avoided, **MAY** result in minor or moderate injury. It may also be used to alert against unsafe practices or property damage.

### **CAUTION**

**CAUTION** used without the safety alert symbol indicates a potentially hazardous situation which, if not avoided, **MAY** result in property damage



**MODEL NUMBER:** This number appears on sales literature, technical manuals and price lists.

**SERIAL NUMBER:** This number appears only on your mower. It contains the model number followed consecutively by the serial number. Use this number when ordering parts or seeking warranty information.

## GENERAL SAFETY

- Read and understand the owner's manual, before attempting to operate this machine.
- Operate all controls from the operator's seat, (if so equipped). **NO RIDERS.**
- Keep all shields in place and safety switches adjusted properly.
- Do not leave equipment unattended. **STOP** the engine and remove the key (if so equipped).
- Do not allow minors or the inexperienced to operate this machine.
- Never allow anyone to operate or service this machine while under the influence of alcohol or drugs.
- Keep people and pets a safe distance away from machines using power driven attachments. Injury could result from flying debris.
- Wear all the necessary protective clothing and personal safety devices to protect your head, eyes, ears, hands, and feet.
- Operate the machine only in daylight or in good artificial light.

## OPERATING SAFETY

1. Remove large objects or debris from the path of the lawn sweeper.
2. Before leaving the tractor seat to clear blockage, service or make adjustments:
  1. **Set PARKING brake.**
  2. **Stop Engine.**
3. Disengage clutches and raise broom to transport position before transporting at high speed.

## OPERATING INSTRUCTIONS

1. Determine hitch position for offset or straight pull position.
2. Transport to clean-up site with the clutches disengaged and sweeper in transport position.
3. Lower the sweeper housing and adjust sweeper height on right side of sweeper housing by choosing the pin location to regulate gauge wheel height.  
**NOTE:** Operation is best when the sweeper is approximately 1/2" below the tips of the grass, but does not "scrub" the lawn.
4. Adjust the float springs allowing the sweeper to "float" over rough areas or high spots in the lawn.
5. Engage clutches on both wheels by rotating the lever approximately 180 degrees.
6. When sweeping leaves - the best results are obtained by sweeping several times during the leaf fall rather than waiting until there is a large accumulation. A large accumulation will require several passes to make a clean sweep. **MAXIMUM SPEED IS 10 M.P.H.**
7. Open rear door to unload.
8. To transport: Always disengage wheel clutches and raise sweeper housing. **DO NOT TRAVEL AT HIGH SPEEDS WITH CLUTCHES ENGAGED! MAXIMUM SPEED IS 10 M.P.H.**  
**NOTE:** To disengage both wheels rotate each lever approximately 180 deg. You can feel a high spot when it is disengaged.

### CAUTION

**Do not travel at high speeds with clutches engaged. MAXIMUM SPEED IS 10 M.P.H.**  
**Disengage clutches for transport. MAXIMUM SPEED IS 10 M.P.H.**

## MAINTENANCE

### Daily

Visually check chain drive - it should not run "dry".

Lube with chain lube or 30W oil

### Weekly or 50 Hours

Grease all bearings and wheels.

Check tire pressure (12 lbs.)

# MAIN PARTS

# LAWN SWEEPER

FIGURE 1

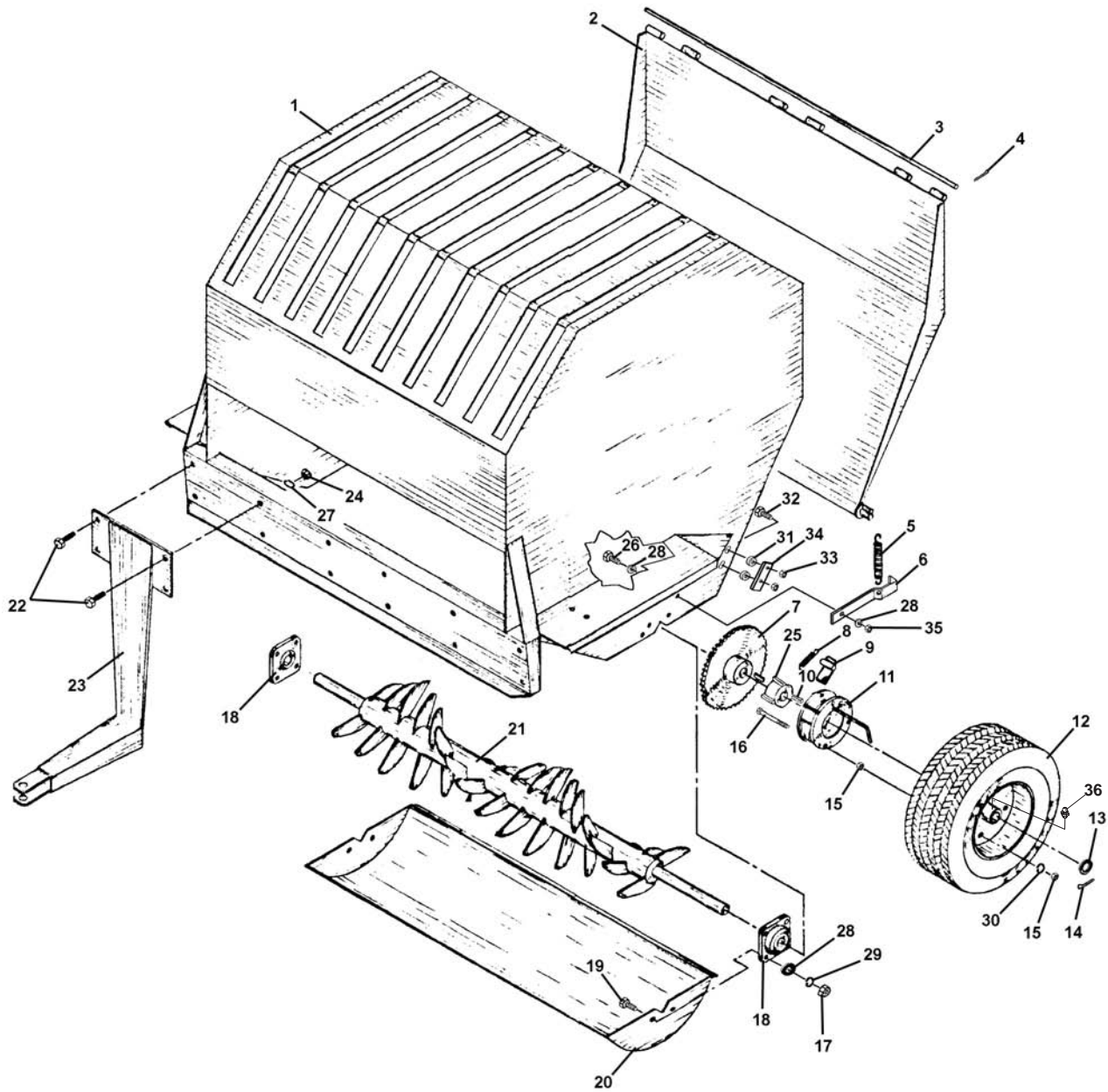



# LAWN SWEEPER

# MAIN PARTS

## FIGURE 1

ITEM	PART NO.	DESCRIPTION	QTY	ITEM	PART NO.	DESCRIPTION	QTY
1-1	62-602.7	MAIN FRAME, LS340	1	1-24	64025-09	HEX, NUT 1/2-13	4
1-2	60-187.7	DOOR	1	1-25	86-044	HUB-CLUTCH DRIVE	2
1-3	42-205.7	HINGE ROD	1	1-26	64123-50	BOLT-HEX 3/8-16X1	2
1-4	64140-1	COTTER PIN-1/8X1	2	1-27	64006-05	LOCKWSHR-HELICAL 1/2	4
1-5	41-010	SPRING	2	1-28	64163-61	WSHR .81X.406X16GA	12
1-6	40-114.7	LATCH-RIGHT	1	1-29	64006-03	LOCKWASHER-3/8 HEL	8
	40-115.7	LATCH-LEFT	1	1-30	64006-02	LOCKWASHER-5/16 HEL	6
1-7	83-407016	SPROCKET	1	1-31	85-SC06	SET COLLAR-3/8 (AFTER SN 1097)	4
1-8	41-013	SPRING	2	1-32	99-K02	BOLT, FLANGE 5/16-18 X 1 (AFTER SN 1097)	4
1-9	86-020.7	CLUTCH PAWL-RIGHT	1	1-33	64141-6	NUT, 5/16-18 (AFTER SN 1097)	4
	86-021.7	CLUTCH PAWL-LEFT	1	1-34	64-535	STOP-ADJUSTABLE LATCH (AFTER SN 1097)	2
1-10	64164-10	1/4X1/4X1-1/4 MACH KEY	3	1-35	64229-03	LOCKNUT-NYLON 3/8-16	2
1-11	86-043.7	CLUTCH	2	1-36	M0005	GREASE FITTING	2
1-12	50-030	WHL & TIRE ASSY	2				
	53-089	TIRE-16X7.50X8	1				
	50-101	RIM	1				
	55-IB-1	BEARING	1				
*	29-053	GREASE FITTING, 1/4-28	2				
1-13	64163-84	WASHER-1.015 X 1.75 X.125	7				
1-14	02-CP0612	COTTER PIN, 3/16 X 1-1/2	2				
1-15	64025-02	NUT-HEX 5/16-18	12				
1-16	64123-66	BLT-HEX 5/16-18X3-1/2	6				
1-17	64025-05	NUT-3/8-16 HEX	8				
1-18	55-FB22016	BEARING	2				
1-19	64123-16	BLT-HEX 3/8-16X1-1/4	8				
1-20	60-188.7	BOTTOM PAN	1				
1-21	80-124.7	PACKER ROTOR	1				
1-22	64123-39	BOLT-HEX 1/2-13X1-1/4	4				
1-23	62-357.7	HITCH	1				

# BRUSH PARTS

# LAWN SWEEPER

FIGURE 2

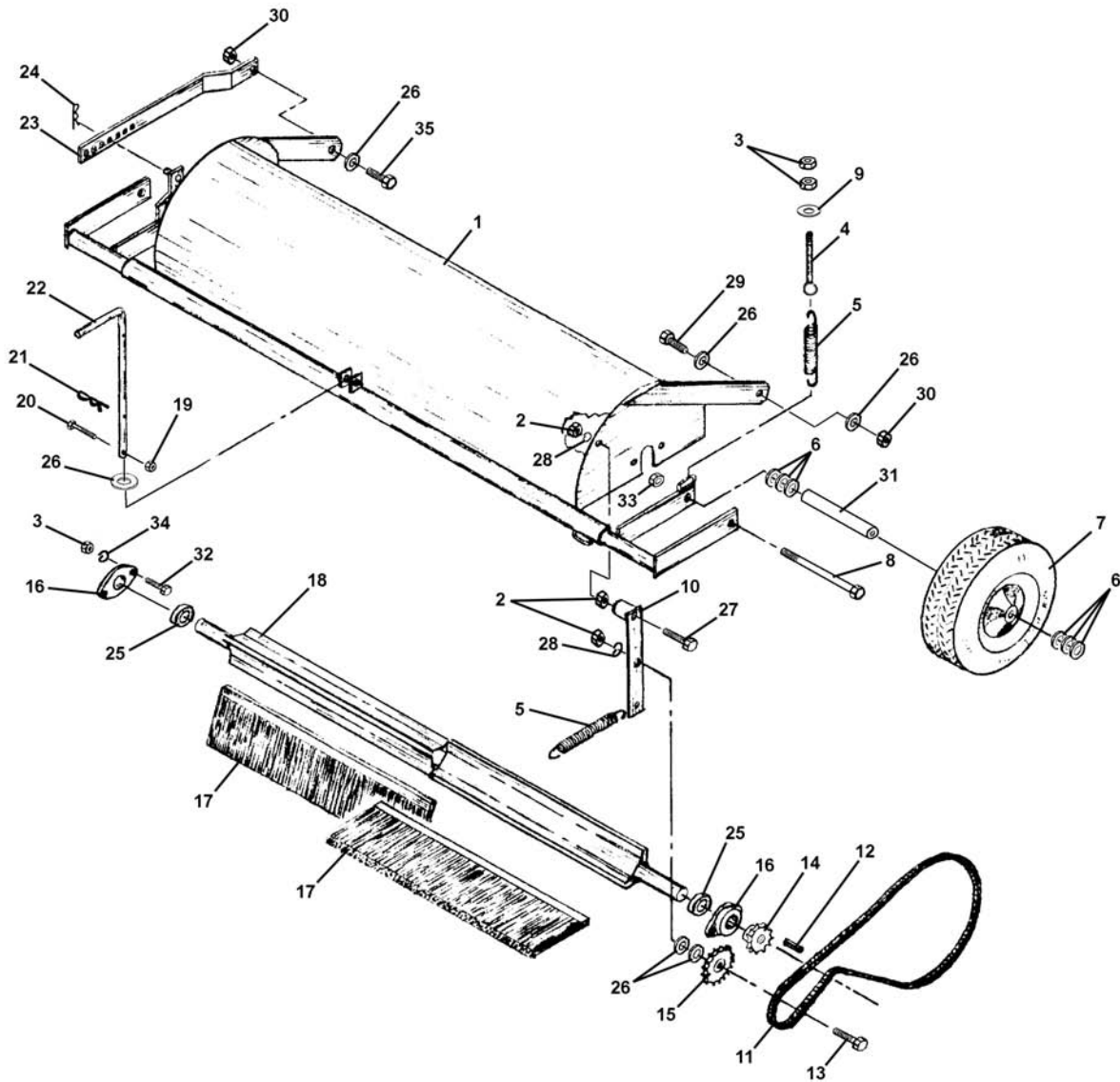

# LAWN SWEEPER

# BRUSH PARTS

## FIGURE 2

ITEM	PART NO.	DESCRIPTION	QTY	ITEM	PART NO.	DESCRIPTION	QTY
2-1	62-385.7	HOUSING, BROOM LS340	1	2-21	02-PP0420	PRESTO PIN, 1/8 X 2-9/16	1
2-2	64025-09	HEX, NUT 1/2-13	3	2-22	42-207.7	HANDLE, LIFT	1
2-3	64025-05	NUT-3/8-16 HEX	8	2-23	42-206.7	HEIGHT ADJUSTER	1
2-4	PL7640	EYEBOLT	2	2-24	02-PP0318	PIN, 3/32 x 2.5/16	1
2-5	41-010	SPRING	3	2-25	85-SC16	SET COLLAR	2
2-6	64163-16	WASHER-41/64 X 1, 3/8 X 12	12	2-26	64163-67	WASHER-.516X1X12GA	6
2-7	53-104	WHL-10.25X3.25 CASTER (SN 1001 - 1559)	2	2-27	64123-72	BLT-HEX 1/2-13X2-1/2	1
	55-G527	BALL BEARING	2	2-28	64006-05	LOCKWSHR-HELICAL 1/2	2
	55-107	BEARING-5/8IDX1-3/8OD (OPTIONAL HEAVY DUTY)	2	2-29	64123-39	BOLT-HEX 1/2-13X1-1/4	1
	53-186	WHL-10.25X3.25 CASTER (SN 1559 - )	2	2-30	64229-05	LOCKNUT, 1/2-13 NYLON	2
	55-112	BRG-ROLLER 5/8IDX1-3/8	1	2-31	50-062	SHAFT-WHEEL	2
	53-187	RETAINER-FLANGED	2	2-32	64123-16	BOLT-3/8 X 1-1/4	4
				2-33	64141-4	NUT-WLF 3/8-16	2
2-8	64123-93	BLT-HEX 3/8-16X5	2	2-34	64006-03	LOCKWASHER-3/8 HEL	4
2-9	64163-61	WSHR .81X.406X16GA	2	2-35	64123-117	BOLT-HEX 1/2-13X1-1/2	1
2-10	40-227.7	IDLER ARM	1				
2-11	56-RC40-59	CHAIN-DRIVE #40 59" LNG	1				
	81-056	CONNECTOR LINK-#40 CHN	1				
	81-076	HALF LINK-#40 CHN	1				
2-12	64164-10	1/4X1/4X1-1/4 MACH KEY	1				
2-13	64123-24	BLT-HEX 1/2-13X2	1				
2-14	83-H401216	SPROCKET	1				
2-15	83-4017E08	IDLER SPROCKET	1				
2-16	55-FB23016	FLANGE BRG-2 BOLT, 1"	2				
2-17	79-017	BRUSH	6				
2-18	80-125.7	ROTOR	1				
2-19	64229-01	LOCKNUT-NYLON 1/4-20	1				
2-20	64123-07	BOLT, 1/4-20X1-1/2 HEX	1				

## **World Class Quality, Performance And Support**



Equipment from Jacobsen, a Textron company, is built to exacting standards ensured by ISO 9001 and ISO 14001 registration at all our manufacturing locations.

A worldwide dealer network and factory-trained technicians backed by Textron Parts Xpress provide reliable, high-quality product support.



---

***BOB-CAT BROWER BUNTON CUSHMAN RYAN STEINER***